

V O L V O



Volvo Excavators 26.0-31.7 t 225 hp

EC250E

Volvo Construction Equipment



Welcome to our world

Welcome to a world of industry leading machinery. A world where imagination, hard work and technological innovation will lead the way towards developing a future which is cleaner, smarter, and more connected. A world supported by the enduring values of the Volvo Group. A world of stability, sustainability and innovation. A world which we put our customers at the heart of.

Welcome to the world of Volvo Construction Equipment – we think you're going to like it here.

Working harder, working smarter

For over 180 years Volvo has been a pioneer in the design and manufacture of machines which set the standard for efficiency, performance and uptime. Across our range of excavators, wheel loaders and haulers, our reputation for engineering excellence is unrivalled, which means whatever your operation or application, we can provide a total fleet solution to help you succeed.

Building on our proud history, the Volvo Concept Lab continues to create cutting-edge ideas and innovative concepts, to ensure we offer customers machines which work harder and smarter long into the future.



Solutions for you

Our industry leading machines are just the start of your relationship with Volvo. As your partner, we have developed an extensive range of additional solutions to help you improve uptime, boost productivity and reduce costs.

Designed for your business

Structured across nine blocks, our portfolio of products and services are designed to complement your machine's performance and boost your profitability. Simply put, we offer some of the best guarantees, warranties and technological solutions in the industry today.

There when you need us

Whether you're buying new or used, our global network of dealers and technicians offer around-the-clock support, including machine monitoring and world-class parts availability. It's the basis of everything offered by Volvo Services, so you can be confident we've got you covered right from the start.

 Fuel Efficiency Services	 Productivity Services	 Safety Services
 Financial Services	 Uptime Services	 Rental Services
 Volvo Attachments	 Genuine Volvo Parts	 New life Services

BUILDING TOMORROW

Giving you more

The new and enhanced EC250E is packed with the latest technology to help you move more, for less. Features including the new Volvo engine, improved hydraulics, flow priority functions and optional Dig Assist apps deliver optimum productivity, efficiency and performance for a lower cost per ton.

More productivity

Get more done in the EC250E thanks to an increase in engine power and improved hydraulic performance which contributes to faster cycle times. Machine productivity is further enhanced by best-in-class stability, new motion priority functions, boom down speed control and improved jack up speed.



More precision

Unlock the full potential of your machine's productivity with Dig Assist, powered by the 10" Volvo Co-Pilot display. Gain access to a set of smart apps, including 2D, In-Field Design, 3D software packages, On-Board Weighing and Volvo Active Control, designed to optimize the digging process.



More control

Double your productivity with Volvo Active Control functions. The working day just got easier with automated boom and bucket movements, making the digging process more accurate and twice as fast. Simply set the grade from the Volvo Co-Pilot display, push the button and get to work – all controlled using a single lever.



More responsiveness

With electric control joystick and full electric travel pedals, operators benefit from an improved response time. Machine controllability is enhanced further by Boom/Swing and Boom/Travel priority functions which enable operators to prioritize one function over another. Operators can also easily adjust the boom down speed, ideal for precision tasks which require optimum control.





MORE FUEL EFFICIENCY

A range of features combine in the EC250E to deliver up to 10% improvement in fuel efficiency. The new D8M Volvo engine reduces rated rpm from 1800 down to 1600, while also delivering a 5% increase in power, and the intelligent new generation electro-hydraulic system provides on-demand flow and reduces internal losses in the hydraulic circuit. Classic Volvo features such as ECO mode and selectable work modes further contribute to outstanding fuel efficiency.

For your comfort and safety

With a host of new and proven features including enhanced machine access, superior visibility, bouncing reduction technology and customizable settings, the upgraded EC250E delivers all the safety and comfort you would expect from your Volvo machine.

Know your limits

With Volvo Active Control, operators can easily set swing fence, height limit and depth limit from the Volvo Co-Pilot. This helps to avoid contact with side obstacles, overhead obstacles such as power lines and underground hazards such as pipes and cables.



See it all

Operators benefit from outstanding visibility thanks to rear and side-view cameras. Furthermore, the optional Volvo Smart View uses front, rear and side cameras to provide a real-time, overhead view of the machine, resulting in safer machine rotation while working, especially in confined spaces.



A smoother shift

New boom and arm bouncing reduction technology reduces machine shock, resulting in a more comfortable and productive operator performance. Comfort Drive Control further helps to reduce fatigue by enabling operators to steer the machine using the joystick rollers instead of the pedals.



How you like it

Get ready for the working day in no time with customizable settings, including preferred control patterns easily selected from the monitor. New 'long push' functionality on the joystick allows operators to set an additional shortcut function, and with the L8 joystick operators can create a shortcut to hydraulic priority functions.





SAFETY, INSIDE AND OUT

Operators can access the upper structure with safety and confidence thanks to the new 3-point right-hand side access. Industry renowned features such as bolted anti-slip steps, high visibility handrails and spacious, ergonomic and low-noise Volvo Care Cab ensure the highest levels of operator comfort and safety.

Boost versatility

Get the most out of your excavator with our range of purpose-built attachments, designed to work in perfect harmony with your machine. Customize your EC250E with quality Volvo attachments, matched to your needs, to form one solid and reliable unit that delivers improved cycle times and increased fuel efficiency.

Buckets of productivity

Volvo buckets are the perfect tool to achieve maximum productivity when digging and re-handling in all conditions. Whether you are working with soft, medium or hard materials, our buckets deliver long life and feature original Volvo wear parts. Heavy-Duty variants provide optimum performance when digging in compact materials.



Take a break

Available with a full range of tools, the HB-Series of hydraulic breakers are designed to be a perfect match for your Volvo. Powered by the machine's constant auxiliary hydraulic flow, the breakers are configured to the specific weights of Volvo machines and are fully compatible with Volvo quick couplers for swift, safe and simple attachment changes.



Dig at any angle

Boost productivity and dig at any angle. Compatibility with SMP®, OilQuick®, Steelwrist®, Engcon® and Rototilt® tiltrotators provides the flexibility needed for precise construction jobs. The factory-fitted preparation system gives you the power to control both the excavator and tiltrotator using the original joysticks, with the information presented on the main display.



Stay cool

A new cooling layout increases hydraulic attachment cooling capacity by 10%, resulting in an improved attachment performance.



SMP® is a registered trademark from SMP Parts AB, OilQuick® is a registered trademark from OilQuick AB, Steelwrist® : Steelwrist is a registered trademark of Steelwrist AB, Engcon® : Engcon is a registered trademark of Engcon Holding AB, Rototilt® : Rototilt is a registered trademark of Rototilt Group AB



EASILY ATTACH

Discover our range of Volvo quick couplers, including the new Steelwrist® Auto Connect Quick Coupler – enabling the quick and easy connection of hydraulic attachments from the comfort and safety of the cab. The quick coupler delivers 300 liters per minute of hydraulic flow directly to the attachment.

Lower maintenance costs

Durable by design, the new EC250E is ready to take on the toughest applications. The machine delivers outstanding levels of reliability and with features including engine auto-regeneration, reinforced components and reduced maintenance requirements, you can count on the EC250E to maximize uptime while keeping maintenance costs to a minimum.

Less service requirements

The new electro-hydraulic system requires less hoses, therefore reducing the need for couplings, minimizing maintenance requirements and increasing reliability. Engine oil and engine oil filter change intervals have been doubled to 1000 hours, further ensuring the time and cost spent on maintenance is kept to a minimum.

Easier UREA filling

The new splash guard on the UREA tank makes filling quicker and easier, while also reducing the risk of spillage and subsequent corrosion.



Up to the challenge

Built to deliver outstanding strength and durability, this heavy-duty production machine features a robust undercarriage with reinforced idle frame, track links and bottom rollers. Reinforced bucket linkage with steel strip, optional heavy-duty superstructure undercover and easily replaced bolt-on wear plates at the arm end ensure the excavator succeeds even on the toughest of jobsites.





POWERED BY EXCELLENCE

With impressively high torque at low rpm, the new D8M Volvo engine builds on generations of proven Volvo engine technology to deliver superior reliability and performance. The engine features auto-regeneration technology, while auto-engine idle and auto-engine shutdown reduce unnecessary fuel consumption and wear.

Boost your profits

A world-class machine is just the start of how Volvo strives to add value you to your operation. Our portfolio of services is designed to complement your machine's performance and boost your profitability.

Every part counts

Maintain productivity and machine uptime with our range of readily available, tested and approved parts – all backed by Volvo warranty. Only by using Genuine Volvo Parts, can you protect your investment, extend machine life and guarantee long-lasting performance.



Maintain performance

Stay on track with planned servicing and keep your asset covered with our range of flexible maintenance and repair options.



Powerful reporting

Keep track of your fleet with a comprehensive portfolio of reports, designed to help you take action and boost the profitability of your business. Powered by the CareTrack telematics system, Productivity Report, Fuel Efficiency Report & Summary Report each provide an easy-to-digest overview of your machine's condition and performance.



Machine monitoring made easy

Maximize machine uptime and reduce repair costs with the CareTrack telematic system. Choose to keep track of your machine yourself or let us take care of it with Volvo Active Care. Our Volvo Uptime Center will provide 24/7 machine monitoring, supplying weekly reports and notifying you should preventive maintenance action be required.





GET THE MOST FROM YOUR MACHINE

While reliable and efficient machines of course play a vital role in reducing costs, enhancing safety and maximizing productivity, it is ultimately the performance of the operator that really makes the difference. We offer a wide range of training initiatives to help operators unlock the full capability of their Volvo excavator.

Move more for less

Boost your productivity

- Best-in-class stability
- Improved response time **NEW**
- Boom/Swing and Boom/Travel priority **NEW**
- Adjustable boom down speed **NEW**
- Dig Assist apps, powered by Volvo Co-Pilot
- Volvo Active Control: double your productivity

Lower maintenance costs

- Less hydraulic hoses: reduced need for couplings/oil **NEW**
- Splash guard on the UREA tank **NEW**
- 1000hr engine oil and engine oil filter change intervals **NEW**
- Engine auto-regeneration **NEW**
- Grouped filters, accessed from ground-level
- Reinforced idle frame, track links, bottom rollers

Comfortable operation

- Boom and arm bouncing reduction **NEW**
- Comfort Drive Control: joysticks steering **NEW**
- Additional 'long push' shortcut button **NEW**
- Selectable control pattern
- Volvo Care Cab: highest levels of comfort

Volvo Services: boost your profits

- Operator training program
- Productivity Report, Fuel Efficiency Report, Summary Report
- ActiveCare: 24/7 machine monitoring
- Genuine Volvo Parts
- Maintenance and repair agreements

Safety, inside and out

- 3-point right-hand side access to the upper structure **NEW**
- Bolted anti-slip steps, high visibility handrails
- ROPS cab, low-noise/vibration
- Rear and side cameras, Volvo Smart View
- Swing fence, height/depth limits functions (Volvo Active Control)

Boost versatility

- Steelwrist® Auto Connect Quick Coupler **NEW**
- Factory-fitted preparation for SMP®, OilQuick®, Steelwrist®, Engcon®, Rototilt® tiltrotator control systems **NEW**
- 10% more hydraulic attachment cooling capacity **NEW**
- Range of matched Volvo buckets and breakers
- Attachment Management System: 32 attachments stored



For a dramatic improvement in fuel efficiency, look no further than the EC250E Hybrid.

Up to 10% better fuel efficiency

- Volvo D8M engine **NEW**
- New generation electro-hydraulic system **NEW**
- ECO mode
- Selectable work modes
- Boom float function
- Auto-engine idle and shutdown



Volvo EC250E in detail

Engine

The next-generation Volvo diesel engine uses Volvo Advanced Combustion Technology (V-ACT) to deliver lower emissions, superior performance and fuel efficiency. The engine uses precise, high-pressure fuel injectors, turbo charger and intercooler, and electronic engine controls to optimize machine performance.

Engine	Volvo	D8M
Max power at	r/min	1 600
Net, ISO 9249/SAE J1349	kW	167
	hp	224
Gross, ISO 14396/SAE J1995	kW	168
	hp	225
Max torque	Nm	1 166
at engine speed	r/min	1 350
No. of cylinders		6
Displacement	l	7.7
Bore	mm	110
Stroke	mm	135

Electrical system

High-capacity electrical system that is well protected. Waterproof double-lock harness plugs are used to secure corrosion-free connections. The main relays and solenoid valves are shielded to prevent damage. The master switch is standard.

Voltage	V	24
Batteries	V	2 x 12
Battery capacity	Ah	170
Alternator	V/A	28 / 120
Start motor	V - kW	24 - 5.5

Undercarriage

The undercarriage has a robust X-shaped frame. Greased and sealed track chains are standard.

Track shoes		2 x 51
Link pitch	mm	190
Shoe width	mm	600 / 700 / 800 / 900
Shoe width, triple grouser	mm	600 / 700 / 800 / 900
Shoe width, triple grouser (HD)	mm	600
Shoe width, double grouser	mm	600 / 700
Bottom rollers		2 x 9
Top rollers		2 x 2

Swing system

The swing system uses an axial piston motors, driving a planetary gearbox for maximum torque. An automatic holding brake and anti-rebound valve are standard.

Max. slew speed	r/min	11.7
Max. slew torque	kNm	91.7

Travel System

Each track is powered by an automatic two-speed shift travel motor. The track brakes are multi-disc, spring-applied and hydraulic released. The travel motor, brake and planetary gears are well protected within the track frame.

Max. drawbar pull	kN	217
Max. travel speed (low)	km/h	3.5
Max. travel speed (high)	km/h	5.5
Gradeability	°	35

Cab

The operator's cab has easy access via a wide door opening. The cab is supported on hydraulic dampening mounts to reduce shock and vibration levels. These along with sound absorbing lining provide low noise levels. The cab has excellent all-round visibility. The front windshield can easily slide up into the ceiling, and the lower front glass can be removed and stored in the side door.

Refrigerant of the type R134a is used when this machine is equipped with air conditioning. Contains fluorinated greenhouse gas R134a, Global Warming Potential 1.430 t CO₂-eq.

Hydraulic system

The hydraulic system, also known as the "Automatic Sensing Work Mode," is designed for high-productivity, high-digging capacity, high-maneuvering precision and excellent fuel economy. The summation system, boom, arm and swing priority along with boom, arm and bucket regeneration provides optimum performance.

Main pump, Type 2 x Variable displacement axial piston pumps

Maximum flow	l/min	2 x 240
--------------	-------	---------

Pilot pump, Type Gear Pump

Maximum flow	l/min	20.3
--------------	-------	------

Relief value setting pressure

Implement	MPa	33.3 / 36.3
Travel circuit	MPa	36.3
Slew circuit	MPa	27.9
Pilot circuit	MPa	3.9

Hydraulic Motors

Travel: Variable displacement axial piston motor with mechanical brake

Swing: Fixed displacement piston motor with mechanical brake

Hydraulic Cylinders

Mono boom		2
Bore x Stroke	ø x mm	135 x 1 345
2 piece boom		2
Bore x Stroke	ø x mm	160 x 1 230
Arm		1
Bore x Stroke	ø x mm	140 x 1 665
Bucket		1
Bore x Stroke	ø x mm	130 x 1 150
Bucket for LR boom		1
Bore x Stroke	ø x mm	100 x 865

Service Refill

Fuel tank	l	472
DEF/AdBlue® tank	l	50
Hydraulic system, total	l	385
Hydraulic tank	l	215
Engine oil	l	30
Engine coolant	l	44
Slew reduction unit	l	5.9
Travel reduction unit	l	2 x 5

Sound Level

Sound pressure level in cab according to ISO 6396

L _{pA}	dB	70
-----------------	----	----

External sound level according to ISO 6395 and EU Noise Directive 2000/14/EC

L _{WA}	dB	104
-----------------	----	-----

Specifications

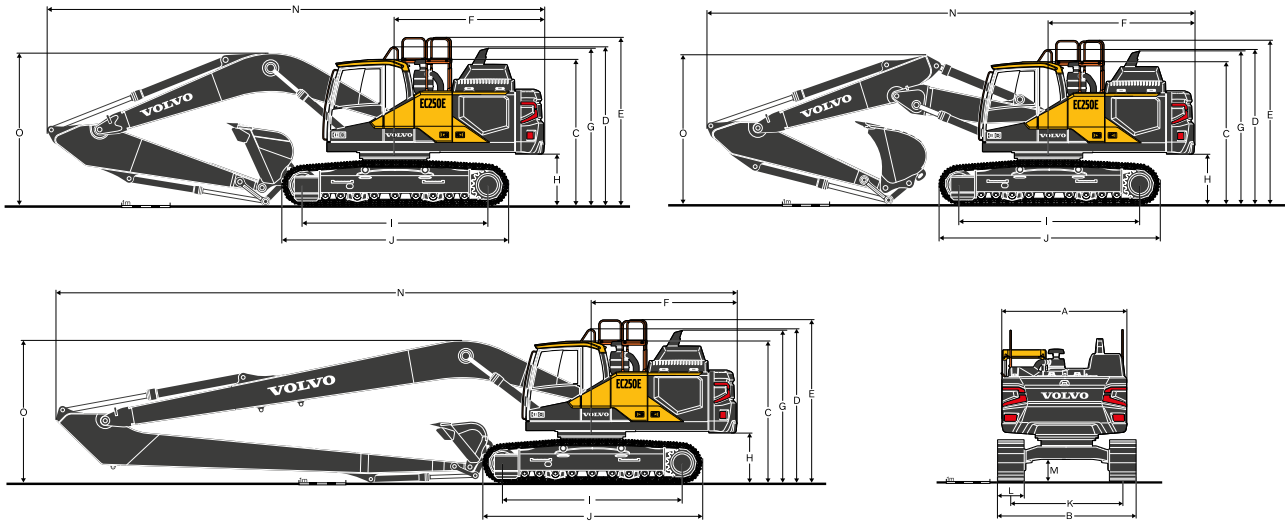

Description	Unit	EC250EL			EC250ENL			EC250EL/EC250ENL			EC250ELR
Boom	m	6.0			6.0			5.95 2-piece			10.2
Arm	m	2.5	2.97	3.6	2.5	2.97	3.6	2.5	2.97	3.6	7.85
A. Overall width of upper structure	mm	2 890	2 890	2 890	2 890	2 890	2 890	2 890	2 890	2 890	2 890
B. Overall width	mm	3 190	3 190	3 190	2 990	2 990	2 990	3 190 / 2 990	3 190 / 2 990	3 190 / 2 990	3 190
C. Overall height of cab	mm	3 045	3 045	3 045	3 045	3 045	3 045	3 045	3 045	3 045	3 045
D. Overall height of handrail	mm	3 310	3 310	3 310	3 310	3 310	3 310	3 310	3 310	3 310	3 310
E. Overall height of guardrail (Unfolded)	mm	3 515	3 515	3 515	3 515	3 515	3 515	3 515	3 515	3 515	3 515
E'. Overall height of handrail/guardrail (Folded)	mm	3 035	3 035	3 035	3 035	3 035	3 035	3 035	3 035	3 035	3 035
F. Tail swing radius	mm	3 075	3 075	3 075	3 075	3 075	3 075	3 075	3 075	3 075	3 155
G. Overall height of diffuser	mm	3 135	3 135	3 135	3 135	3 135	3 135	3 135	3 135	3 135	3 135
H. Counterweight clearance *	mm	1 045	1 045	1 045	1 045	1 045	1 045	1 045	1 045	1 045	1 045
I. Tumbler length	mm	3 850	3 850	3 850	3 850	3 850	3 850	3 850	3 850	3 850	3 850
J. Track length	mm	4 650	4 650	4 650	4 650	4 650	4 650	4 650	4 650	4 650	4 650
K. Track gauge	mm	2 590	2 590	2 590	2 390	2 390	2 390	2 590 / 2 390	2 590 / 2 390	2 590 / 2 390	2 590
L. Shoe width	mm	600	600	600	600	600	600	600	600	600	600
M. Min. ground clearance *	mm	470	470	470	470	470	470	470	470	470	470
N. Overall length	mm	10 310	10 230	10 300	10 310	10 230	10 300	10 260	10 225	10 230	14 520
O. Overall height of boom	mm	3 330	3 110	3 330	3 330	3 110	3 330	3 265	3 185	3 405	3 080

* Without shoe grouser

' 2-piece boom

DIMENSIONS

Boom						Arm						
Description	Unit			2-piece	Long-Reach	Description	Unit				Long-Reach	
Boom	m	6.0 GP	6.0 HD	5.95	10.2	Arm	m	2.5 HD_S	2.97 GP_S	2.97 HD_S	3.6 GP_S	7.85
Length	mm	6 220	6 220	6 170	10 420	Length	mm	3 580	4 050	4 050	4 715	8 960
Height	mm	1 750	1 750	1 510	1 525	Height	mm	995	995	995	1 000	1 190
Width	mm	725	725	725	725	Width	mm	510	510	510	510	385
Weight	kg	2 230	2 355	2 835	3 025	Weight	kg	1 210	1 245	1 300	1 335	1 630

* Includes cylinder, piping and pin, excludes boom cylinder pin

* Includes cylinder, linkage and pin

Specifications

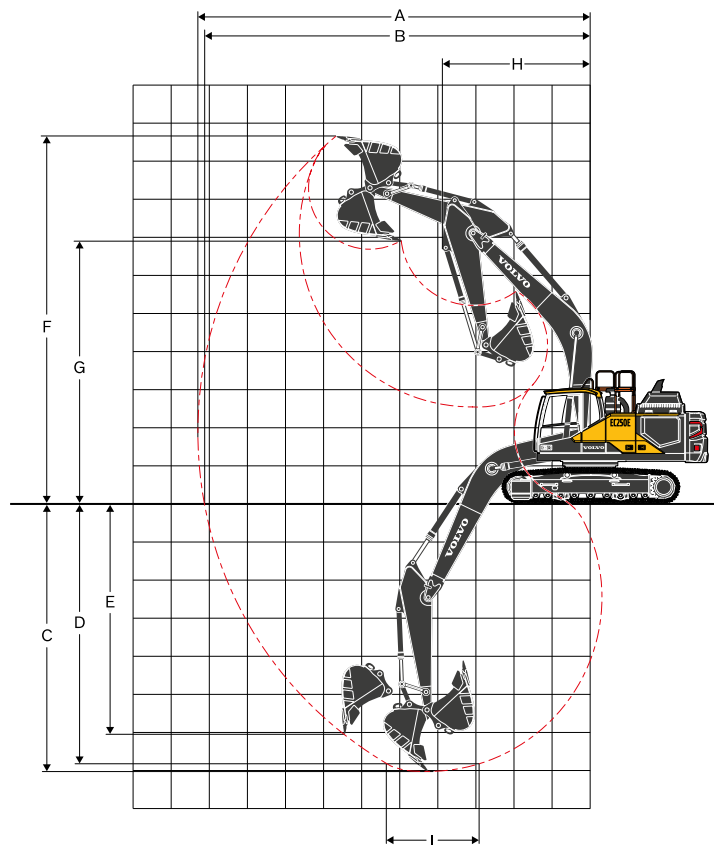
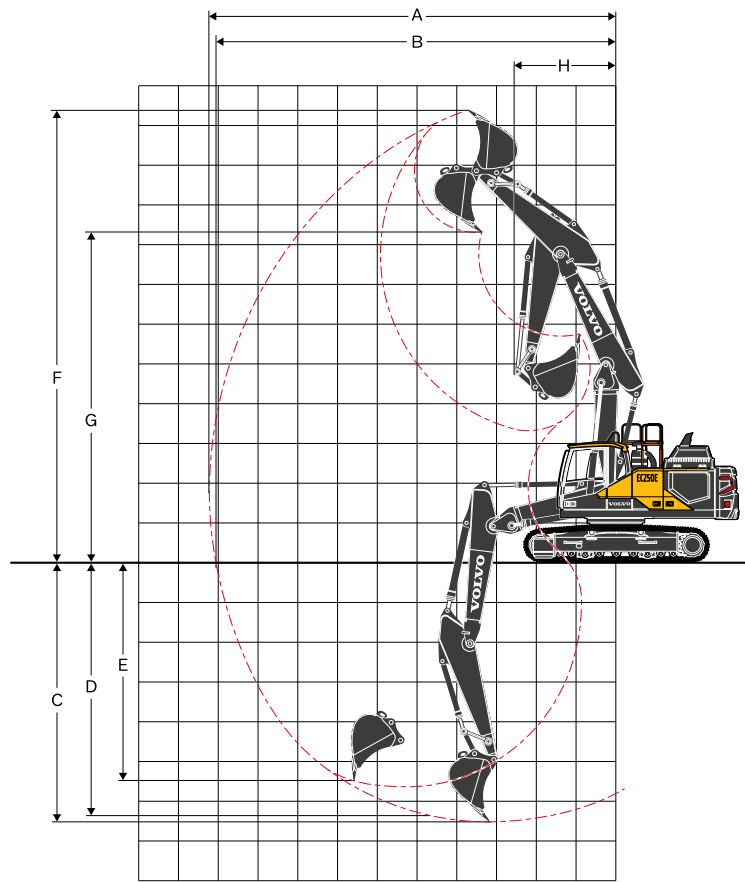

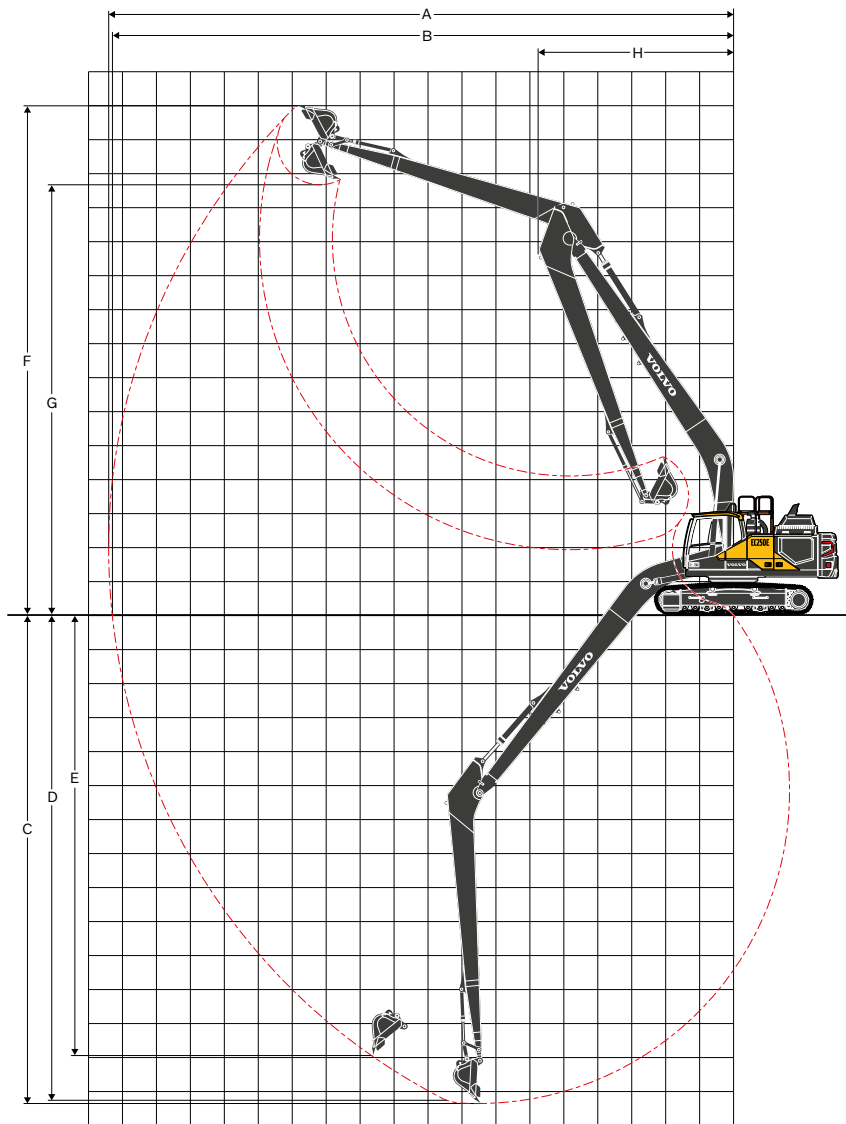

WORKING RANGES

Description	Unit	EC250EL / EC250ENL						EC250ELR
Boom	m	6.0			5.95 2-piece			10.2
Arm	m	2.5	2.97	3.6	2.5	2.97	3.6	7.85
A. Max. digging reach	mm	9 960	10 340	10 810	9 970	10 365	10 855	18 305
B. Max. digging reach on ground	mm	9 775	10 160	10 640	9 785	10 190	10 685	18 210
C. Max. digging depth	mm	6 590	7 060	7 690	6 125	6 565	7 135	14 350
D. Max. digging depth (2.44 m level)	mm	6 375	6 855	7 470	6 020	6 465	7 040	14 240
E. Max. vertical wall digging depth	mm	5 265	5 520	5 805	4 910	5 290	5 765	12 470
F. Max. cutting height	mm	9 620	9 685	9 645	11 140	11 390	11 625	14 890
G. Max. dumping height	mm	6 610	6 710	6 730	7 925	8 190	8 445	12 580
H. Min. front swing radius	mm	3 915	3 890	3 890	2 785	2 550	2 715	5 720

DIGGING FORCES WITH DIRECT FIT BUCKET

Bucket radius	mm	1 620	1 620	1 620	1 620	1 620	1 620	1 248		
Breakout force	Normal	SAE J1179	kN	145	145	145	145	145	68	
			Power boost	kN	157	157	157	157	157	68
	Normal	ISO 6015	kN	166	166	166	166	166	77	
			Power boost	kN	181	181	181	181	181	77
Tearout force	Normal	SAE J1179	kN	132	114	102	132	114	102	43
			Power boost	kN	143	124	111	143	124	111
	Normal	ISO 6015	kN	136	118	105	136	118	105	43
			Power boost	kN	148	128	114	148	128	114
Rotation angle, bucket	°	177	177	177	177	177	177	178		

Specifications

MACHINE WEIGHTS AND GROUND PRESSURE

Description	Shoe width	Operating weight	Ground pressure	Overall width	Operating weight	Ground pressure	Overall width
	mm	kg	kPa	mm	kg	kPa	mm
EC250EL							
		6.0 m boom (GP), 2.97 m arm (GP), 1 200 kg / 1.14 m³ bucket, 4 950 kg counterweight			6.0 m boom (HD), 2.97 m arm (HD), 1 200 kg / 1.14 m³ bucket, 4 950 kg counterweight		
Triple grouser	600	26 830	53.0	3 190	27 010	53.4	3 190
	600 (HD)	27 070	53.5	3 190	27 250	53.8	3 190
	700	27 130	45.9	3 290	27 310	46.2	3 290
	800	27 420	40.6	3 390	27 600	40.9	3 390
	900	27 730	36.5	3 490	27 910	36.8	3 490
Double grouser	600	27 050	53.4	3 290	27 230	53.8	3 190
	700	27 390	46.4	3 290	27 570	46.7	3 290
		5.95 m boom (2-piece), 2.97 m arm (GP), 1 200 kg / 1.14 m³ bucket, 4 950 kg counterweight			5.95 m boom (2-piece), 2.97 m arm (HD), 1 200 kg / 1.14 m³ bucket, 4 950 kg counterweight		
Triple grouser	600	27 440	54.2	3 190	27 490	54.3	3 190
	600 (HD)	27 680	54.7	3 190	27 730	54.8	3 190
	700	27 740	47.0	3 290	27 790	47.1	3 290
	800	28 030	41.5	3 390	28 080	41.6	3 390
	900	28 340	37.3	3 490	28 390	37.4	3 490
Double grouser	600	27 660	54.6	3 290	27 710	54.7	3 190
	700	28 000	47.4	3 290	28 050	47.5	3 290
EC250ENL							
		6.0 m boom (GP), 2.97 m arm (GP), 1 200 kg / 1.14 m³ bucket, 4 950 kg counterweight			6.0 m boom (HD), 2.97 m arm (HD), 1 200 kg / 1.14 m³ bucket, 4 950 kg counterweight		
Triple grouser	600	26 750	52.8	2 990	26 920	53.2	2 990
	600 (HD)	26 990	53.3	2 990	27 160	53.7	2 990
	700	27 050	45.8	3 090	27 220	46.1	3 090
	800	27 340	40.5	3 190	27 510	40.8	3 190
	900	27 650	36.4	3 290	27 820	36.6	3 290
Double grouser	600	26 970	53.3	2 990	27 140	53.6	2 990
	700	27 310	46.2	3 090	27 480	46.5	3 090
		5.95 m boom (2-piece), 2.97 m arm (GP), 1 200 kg / 1.14 m³ bucket, 4 950 kg counterweight			5.95 m boom (2-piece), 2.97 m arm (HD), 1 200 kg / 1.14 m³ bucket, 4 950 kg counterweight		
Triple grouser	600	27 360	54.0	2 990	27 410	54.1	2 990
	600 (HD)	27 600	54.5	2 990	27 650	54.6	2 990
	700	27 660	46.8	3 090	27 710	46.9	3 090
	800	27 950	41.4	3 190	28 000	41.5	3 190
	900	28 260	37.2	3 290	28 310	37.3	3 290
Double grouser	600	27 580	54.5	2 990	27 630	54.6	2 990
	700	27 920	47.3	3 090	27 970	47.4	3 090
EC250ELR							
		10.2 m boom (LR), 7.85 m arm (LR), 452 kg / 0.52 m³ bucket, 6 200 kg counterweight					
Triple grouser	600	28 570	57.6	3 190			
	600 (HD)	28 810	56.9	3 190			
	800	29 160	44.1	3 390			
	900	29 470	39.6	3 490			

BUCKET SELECTION GUIDE

Bucket type		Capacity	Cutting width	Weight	Teeth	EC250EL						EC250ENL					
						600 mm shoe, 4 950 kg counterweight						600 mm shoe, 4 950 kg counterweight					
						6.0 m GP Boom			5.95 m 2-piece Boom			6.0 m GP Boom			5.95 m 2-piece Boom		
						L	mm	kg	EA	2.5 m	2.97 m	3.6 m	2.5 m	2.97 m	3.6 m	2.5 m	2.97 m
Direct fit bucket	General purpose	560	600	800	3	C	C	C	C	C	C	C	C	C	C	C	C
		620	750	823	3	C	C	C	C	C	C	C	C	C	C	C	C
		770	900	983	4	C	C	C	C	C	C	C	C	C	C	C	C
		950	1090	1012	4	C	C	C	C	C	C	C	C	C	C	C	C
		1140	1240	1179	5	C	C	C	C	C	C	C	C	C	C	C	C
		1320	1390	1196	5	C	C	C	C	C	C	C	C	C	C	C	C
		1450	1490	1249	5	C	C	C	C	C	C	C	C	B	C	C	B
		1510	1540	1294	5	C	C	C	C	C	C	C	C	B	C	C	B
	1760	1740	1435	6	C	B	B	C	B	A	B	B	A	B	A	X	
	Heavy duty	560	600	870	3	D	D	D	D	D	D	D	D	D	D	D	D
		620	750	880	3	D	D	D	D	D	D	D	D	D	D	D	D
		1140	1240	1200	5	D	D	D	D	D	D	D	D	D	D	D	D
		1320	1390	1289	5	D	D	D	D	D	D	D	D	C	D	D	C
		1510	1540	1377	5	D	D	C	D	D	B	C	C	B	C	B	B
1760		1740	1533	6	C	B	A	B	B	A	B	A	B	B	A	X	
Direct fit bucket (UQC interface)	General purpose	560	600	800	3	C	C	C	C	C	C	C	C	C	C	C	C
		620	750	823	3	C	C	C	C	C	C	C	C	C	C	C	C
		770	900	983	4	C	C	C	C	C	C	C	C	C	C	C	C
		950	1090	1012	4	C	C	C	C	C	C	C	C	C	C	C	C
		1140	1240	1179	5	C	C	C	C	C	C	C	C	B	C	C	B
		1320	1390	1196	5	C	C	C	C	C	B	C	B	B	C	B	A
		1450	1490	1249	5	C	C	B	C	B	B	B	B	A	B	B	x
		1510	1540	1294	5	C	B	A	C	B	A	B	B	x	B	A	x
	1760	1740	1435	6	B	A	x	B	A	x	A	x	x	A	x	x	
	Heavy duty	560	600	870	3	D	D	D	D	D	D	D	D	D	D	D	D
		620	750	880	3	D	D	D	D	D	D	D	D	D	D	D	D
		1140	1240	1200	5	D	D	D	D	D	C	D	D	B	D	C	B
		1320	1390	1289	5	D	C	B	D	C	B	C	B	A	C	B	A
		1510	1540	1377	5	C	B	A	C	B	A	B	A	x	B	A	x
1760		1740	1533	6	B	A	x	A	A	x	A	x	x	A	x	x	

For long reach boom and arm configuration, Volvo recommends to use 0.52 m³ (0.68 yd³) bucket
Please consult with your Volvo dealer for the proper match of buckets and attachments to suit the application.
The recommendations are given as a guide only, based on typical operation conditions.
Bucket capacity based on ISO 7451, heaped material with a 1:1 angle of repose.

Maximum material density	
A	1 200~1 300 kg/m ³ Coal, Caliche, Shale
B	1 400~1 600 kg/m ³ Wet earth and clay, Limestone, Sandstone
C	1 700~1 800 kg/m ³ Granite, Wet sand, Well blasted rock
D	> 1 900 kg/m ³ Wet mud, Iron ore
X	Not recommended

Specifications

LIFTING CAPACITY EC250EL

Lifting capacity at the arm end without bucket.

For lifting capacity including bucket, simply subtract actual weight of the direct fit bucket or the bucket with quick coupler from the following values.

	Lifting point	1.5 m		3.0 m		4.5 m		6.0 m		7.5 m		9.0 m		Max. reach		m
		Along UC	Across UC	Along UC	Across UC	Along UC	Across UC	Along UC	Across UC	Along UC	Across UC	Along UC	Across UC	Along UC	Across UC	
Boom: 6.0 m Arm: 2.5 m Shoe: 600 mm CWT: 4 950 kg	7.5 m kg							*6 890	*6 890					*6 940	*6 940	6.1
	6.0 m kg							*6 900	*6 900					*6 930	5 540	7.2
	4.5 m kg					*9 320	*9 320	*7 740	7 250	*7 100	5 140			6 960	4 720	7.9
	3.0 m kg					*12 020	10 510	*8 950	6 930	7 430	5 000			6 400	4 320	8.3
	1.5 m kg					*14 100	9 930	*10 090	6 630	7 270	4 850			6 230	4 180	8.3
	0 m kg					*14 870	9 690	9 960	6 440	7 150	4 750			6 400	4 270	8.1
	-1.5 m kg			*10 440	*10 440	*14 660	9 650	9 880	6 370	7 120	4 720			7 000	4 650	7.6
	-3.0 m kg			*18 690	*18 690	*13 560	9 750	9 940	6 430					8 450	5 550	6.7
	-4.5 m kg			*14 940	*14 940	*10 900	10 030							*9 080	8 030	5.2
	Boom: 6.0 m Arm: 2.97 m Shoe: 600 mm CWT: 4 950 kg	7.5 m kg													*6 080	*6 080
6.0 m kg								*6 330	*6 330	*6 390	5 300			*5 830	5 120	7.7
4.5 m kg						*8 430	*8 430	*7 220	*7 220	*6 670	5 210			*5 860	4 420	8.3
3.0 m kg						*11 140	10 720	*8 490	7 020	*7 280	5 050			6 010	4 070	8.6
1.5 m kg						*13 500	10 970	*9 740	6 700	7 300	4 890			5 850	3 940	8.7
0 m kg				*5 020	*5 020	*14 680	9 730	9 990	6 470	7 160	4 760			5 980	4 000	8.5
-1.5 m kg		*6 670	*6 670	*10 700	*10 700	*14 820	9 620	9 860	6 360	7 090	4 690			6 470	4 310	8.0
-3.0 m kg		*12 360	*12 360	*17 780	*17 780	*14 040	9 670	9 880	6 370					7 610	5 020	7.2
-4.5 m kg				*16 720	*16 720	*12 000	9 880							*8 940	6 810	5.8
Boom: 6.0 m Arm: 3.6 m Shoe: 600 mm CWT: 4 950 kg		7.5 m kg													*5 040	*5 040
	6.0 m kg									*5 650	5 400			*4 900	4 640	8.2
	4.5 m kg							*6 430	*6 430	*6 060	5 270			*4 950	4 060	8.8
	3.0 m kg			*15 760	*15 760	*9 850	*9 850	*7 750	7 110	*6 750	5 090	*5 650	3 830	*5 180	3 750	9.1
	1.5 m kg					*12 490	10 210	*9 130	6 740	7 320	4 890	5 560	3 730	5 400	3 630	9.2
	0 m kg			*7 080	*7 080	*14 150	9 740	9 990	6 460	7 140	4 730			5 490	3 660	9.0
	-1.5 m kg	*6 800	*6 800	*10 800	*10 800	*14 740	9 540	9 810	6 300	7 030	4 630			5 870	3 900	8.5
	-3.0 m kg	*11 030	*11 030	*16 000	*16 000	*14 400	9 520	9 760	6 260	7 020	4 620			6 730	4 440	7.7
	-4.5 m kg	*16 340	*16 340	*18 580	*18 580	*12 990	9 660	*9 600	6 360					*8 610	5 690	6.5
	-6.0 m kg					*9 450	*9 450							*9 390	*9 390	4.5
Boom: 6.0 m Arm: 2.5 m Shoe: 800 mm CWT: 4 950 kg	7.5 m kg							*6 880	*6 880					*6 930	*6 930	6.1
	6.0 m kg							*6 890	*6 890					*6 910	5 640	7.2
	4.5 m kg					*9 310	*9 310	*7 730	7 390	*7 070	5 240			*7 040	4 810	7.9
	3.0 m kg					*11 980	10 690	*8 920	7 050	7 580	5 090			6 530	4 400	8.3
	1.5 m kg					*14 050	10 090	*10 050	6 750	7 410	4 940			6 350	4 250	8.3
	0 m kg					*14 800	9 840	10 150	6 550	7 290	4 830			6 520	4 340	8.1
	-1.5 m kg			*10 440	*10 440	*14 590	9 790	10 060	6 470	7 250	4 790			7 130	4 720	7.6
	-3.0 m kg			*18 580	*18 580	*13 480	9 890	*10 090	6 520					8 610	5 640	6.7
	-4.5 m kg			*14 840	*14 840	*10 830	10 170							*9 020	8 150	5.2
	Boom: 6.0 m Arm: 2.97 m Shoe: 800 mm CWT: 4 950 kg	7.5 m kg													*6 050	*6 050
6.0 m kg								*6 280	*6 280	*6 330	5 370			*5 800	5 180	7.7
4.5 m kg						*8 390	*8 390	*7 170	*7 170	*6 620	5 280			*5 830	4 470	8.3
3.0 m kg						*11 080	10 890	*8 430	7 120	*7 220	5 120			*6 070	4 110	8.6
1.5 m kg						*13 410	10 200	*9 660	6 780	7 420	4 940			5 940	3 970	8.7
0 m kg				*4 990	*4 990	*14 580	9 850	10 150	6 540	7 270	4 810			6 070	4 040	8.5
-1.5 m kg		*6 640	*6 640	*10 660	*10 660	*14 700	9 740	10 020	6 430	7 200	4 740			6 570	4 350	8.0
-3.0 m kg		*12 320	*12 320	*17 740	*17 740	*13 930	9 780	10 030	6 440					7 720	5 070	7.2
-4.5 m kg				*16 570	*16 570	*11 890	10 000							*8 850	6 880	5.8
Boom: 6.0 m Arm: 3.6 m Shoe: 800 mm CWT: 4 950 kg		7.5 m kg													*5 040	*5 040
	6.0 m kg									*5 640	5 500			*4 900	4 730	8.2
	4.5 m kg							*6 420	*6 420	*6 050	5 380			*4 950	4 140	8.8
	3.0 m kg			*15 730	*15 730	*9 830	*9 830	*7 730	7 250	*6 730	5 190	*5 650	3 900	*5 180	3 820	9.1
	1.5 m kg					*12 450	10 390	*9 100	6 860	7 470	4 980	5 670	3 800	5 510	3 690	9.2
	0 m kg			*7 080	*7 080	*14 100	9 900	*10 160	6 570	7 280	4 810			5 600	3 730	9.0
	-1.5 m kg	*6 800	*6 800	*10 800	*10 800	*14 670	9 690	10 000	6 400	7 170	4 710			5 980	3 960	8.5
	-3.0 m kg	*11 030	*11 030	*16 000	*16 000	*14 330	9 670	9 950	6 360	7 160	4 700			6 850	4 510	7.7
	-4.5 m kg	*16 340	*16 340	*18 470	*18 470	*12 920	9 810	*9 550	6 460					*8 560	5 770	6.5
	-6.0 m kg					*9 380	*9 380							*9 330	*9 330	4.5

Notes: 1. Machine in "Fine Mode-F" (Power Boost) for lifting capacities. 2. The above loads are in compliance with SAE J1097 and ISO 10567 Hydraulic Excavator Lifting Capacity Standards. 3. Rated loads do not exceed 87% of hydraulic lifting capacity or 75% of tipping load. 4. Rated loads marked with an asterisk (*) are limited by hydraulic capacity rather than tipping load.

LIFTING CAPACITY EC250EL

Lifting capacity at the arm end without bucket.

For lifting capacity including bucket, simply subtract actual weight of the direct fit bucket or the bucket with quick coupler from the following values.

	Lifting point	1.5 m		3.0 m		4.5 m		6.0 m		7.5 m		9.0 m		Max. reach		m	
		Along UC	Across UC	Along UC	Across UC	Along UC	Across UC	Along UC	Across UC	Along UC	Across UC	Along UC	Across UC	Along UC	Across UC		
Boom: 5.95 m 2-piece Arm: 2.5 m Shoe: 600 mm CWT: 4 950 kg	9.0 m kg														*9 630	*9 630	4.2
	7.5 m kg					*9 810	*9 810	*8 570	7 430						*8 030	7 170	6.1
	6.0 m kg					*10 060	*10 060	*9 010	7 400						*7 530	5 420	7.2
	4.5 m kg					*12 130	11 170	*9 600	7 150	7 520	5 040				6 880	4 610	7.9
	3.0 m kg					*13 960	10 350	*10 360	6 810	7 370	4 900				6 330	4 220	8.3
	1.5 m kg					*14 790	9 760	10 090	6 510	7 210	4 760				6 160	4 090	8.3
	0 m kg					*14 170	9 530	9 890	6 330	7 100	4 660				6 350	4 190	8.1
	-1.5 m kg			*10 240	*10 240	*12 510	9 530	*9 680	6 280	7 100	4 660				*6 880	4 580	7.6
	-3.0 m kg					*9 730	9 680	*7 470	6 380						*6 010	5 510	6.7
Boom: 5.95 m 2-piece Arm: 2.97 m Shoe: 600 mm CWT: 4 950 kg	9.0 m kg					*7 830	*7 830								*6 870	*6 870	5.0
	7.5 m kg					*7 800	*7 800	*7 460	*7 460						*5 960	*5 960	6.6
	6.0 m kg					*7 990	*7 990	*8 300	7 510	*6 470	5 180				*5 660	4 950	7.7
	4.5 m kg			*16 230	*16 230	*11 400	11 380	*9 190	7 240	7 580	5 090				*5 640	4 270	8.3
	3.0 m kg					*13 370	10 550	*10 040	6 880	7 400	4 930				*5 820	3 930	8.7
	1.5 m kg					*14 620	9 860	10 140	6 540	7 210	4 760				5 750	3 810	8.7
	0 m kg					*14 490	9 520	9 880	6 320	7 080	4 640				5 890	3 880	8.5
	-1.5 m kg			*10 490	*10 490	*13 190	9 450	9 780	6 230	7 030	4 590				6 390	4 200	8.0
	-3.0 m kg					*10 790	9 550	*8 290	6 280						*6 120	4 930	7.2
Boom: 5.95 m 2-piece Arm: 3.6 m Shoe: 600 mm CWT: 4950 kg	9.0 m kg														*5 510	*5 510	5.8
	7.5 m kg							*6 460	*6 460						*4 960	*4 960	7.3
	6.0 m kg							*6 830	*6 830	*6 280	5 320				*4 780	4 510	8.2
	4.5 m kg			*7 580	*7 580	*8 160	*8 160	*8 090	7 400	*7 370	5 190				*4 790	3 940	8.8
	3.0 m kg					*12 480	10 850	*9 560	7 010	7 480	5 000	5 610	3 750		*4 970	3 640	9.2
	1.5 m kg					*14 170	10 040	10 240	6 620	7 260	4 800	5 510	3 650		5 310	3 520	9.2
	0 m kg			*6 890	*6 890	*14 630	9 560	9 910	6 340	7 080	4 640	5 430	3 580		5 410	3 570	9.0
	-1.5 m kg			*10 640	*10 640	*13 860	9 380	9 740	6 190	6 990	4 550				5 790	3 810	8.6
	-3.0 m kg			*15 820	*15 820	*11 980	9 410	*9 120	6 180	*6 730	4 570				*6 220	4 360	7.8
-4.5 m kg					*8 710	*8 710	*6 450	6 330								6.6	

Notes: 1. Machine in "Fine Mode-F" (Power Boost) for lifting capacities. 2. The above loads are in compliance with SAE J1097 and ISO 10567 Hydraulic Excavator Lifting Capacity Standards. 3. Rated loads do not exceed 87% of hydraulic lifting capacity or 75% of tipping load. 4. Rated loads marked with an asterisk (*) are limited by hydraulic capacity rather than tipping load.

Specifications

LIFTING CAPACITY EC250ENL

Lifting capacity at the arm end without bucket.

For lifting capacity including bucket, simply subtract actual weight of the direct fit bucket or the bucket with quick coupler from the following values.

	Lifting point	1.5 m		3.0 m		4.5 m		6.0 m		7.5 m		9.0 m		Max. reach		m
		Along UC	Across UC	Along UC	Across UC	Along UC	Across UC	Along UC	Across UC	Along UC	Across UC	Along UC	Across UC	Along UC	Across UC	
Boom: 6.0 m Arm: 2.5 m Shoe: 600 mm CWT: 4 950 kg	7.5 m kg							*6 890	*6 890					*6 940	6 750	6.1
	6.0 m kg							*6 900	*6 900					*6 930	5 110	7.2
	4.5 m kg					*9 320	*9 320	*7 740	6 670	*7 100	4 740			6 940	4 350	7.9
	3.0 m kg					*12 020	9 560	*8 950	6 360	7 410	4 600			6 380	3 970	8.3
	1.5 m kg					*14 100	9 000	*10 090	6 070	7 250	4 450			6 210	3 840	8.3
	0 m kg					*14 870	8 760	9 930	5 880	7 130	4 350			6 380	3 910	8.1
	-1.5 m kg			*10 440	*10 440	*14 660	8 730	9 850	5 810	7 100	4 320			6 980	4 260	7.6
	-3.0 m kg			*18 690	17 210	*13 560	8 820	9 910	5 870					8 420	5 080	6.7
	-4.5 m kg			*14 940	*14 940	*10 900	9 090							*9 080	7 320	5.2
Boom: 6.0 m Arm: 2.97 m Shoe: 600 mm CWT: 4 950 kg	7.5 m kg													*6 080	6 040	6.6
	6.0 m kg							*6 330	*6 330	*6 390	4 900			*5 830	4 720	7.7
	4.5 m kg					*8 430	*8 430	*7 220	6 780	*6 670	4 810			*5 860	4 070	8.3
	3.0 m kg					*11 140	9 760	*8 490	6 450	*7 280	4 650			5 990	3 740	8.6
	1.5 m kg					*13 500	9 130	*9 740	6 130	7 280	4 480			5 830	3 610	8.7
	0 m kg			*5 020	*5 020	*14 680	8 800	9 960	5 910	7 140	4 360			5 960	3 670	8.5
	-1.5 m kg	*6 670	*6 670	*10 700	*10 700	*14 820	8 700	9 830	5 800	7 070	4 300			6 450	3 940	8.0
	-3.0 m kg	*12 360	*12 360	*17 780	17 030	*14 040	8 750	9 850	5 810					7 590	4 600	7.2
	-4.5 m kg			*16 720	*16 720	*12 000	8 950							*8 940	6 220	5.8
Boom: 6.0 m Arm: 3.6 m Shoe: 600 mm CWT: 4 950 kg	7.5 m kg													*5 040	*5 040	7.2
	6.0 m kg									*5 650	4 990			*4 900	4 290	8.2
	4.5 m kg							*6 430	*6 430	*6 060	4 870			*4 950	3 740	8.8
	3.0 m kg			*15 760	*15 760	*9 850	*9 850	*7 750	6 530	*6 750	4 680	5 640	3 520	*5 180	3 450	9.1
	1.5 m kg					*12 490	9 270	*9 130	6 170	7 300	4 490	5 540	3 420	5 380	3 330	9.2
	0 m kg			*7 080	*7 080	*14 150	8 810	9 960	5 900	7 120	4 330			5 470	3 360	9.0
	-1.5 m kg	*6 800	*6 800	*10 800	*10 800	*14 740	8 610	9 780	5 740	7 010	4 230			5 850	3 560	8.5
	-3.0 m kg	*11 030	*11 030	*16 000	*16 000	*14 400	8 600	9 730	5 700	7 000	4 220			6 710	4 060	7.7
	-4.5 m kg	*16 340	*16 340	*18 580	17 010	*12 990	8 740	*9 600	5 800					*8 610	5 190	6.5
-6.0 m kg					*9 450	9 110							*9 390	9 050	4.5	
Boom: 5.95 m 2-piece Arm: 2.5 m Shoe: 600 mm CWT: 4 950 kg	9.0 m kg													*9 630	*9 630	4.2
	7.5 m kg					*9 810	*9 810	*8 570	6 830					*8 030	6 600	6.1
	6.0 m kg					*10 060	*10 060	*9 010	6 810					*7 530	4 980	7.2
	4.5 m kg					*12 130	10 180	*9 600	6 570	7 500	4 630			6 860	4 230	7.9
	3.0 m kg					*13 960	9 390	*10 360	6 230	7 350	4 500			6 310	3 870	8.3
	1.5 m kg					*14 790	8 810	10 060	5 940	7 190	4 350			6 150	3 740	8.3
	0 m kg					*14 170	8 600	9 860	5 760	7 080	4 260			6 330	3 830	8.1
	-1.5 m kg			*10 240	*10 240	*12 510	8 590	*9 680	5 710	7 080	4 260			*6 880	4 190	7.6
	-3.0 m kg					*9 730	8 740	*7 470	5 810					*6 010	5 030	6.7
Boom: 5.95 m 2-piece Arm: 2.97 m Shoe: 600 mm CWT: 4 950 kg	9.0 m kg					*7 830	*7 830							*6 870	*6 870	5.0
	7.5 m kg					*7 800	*7 800	*7 460	6 990					*5 960	5 840	6.6
	6.0 m kg					*7 990	*7 990	*8 300	6 910	*6 470	4 760			*5 660	4 560	7.7
	4.5 m kg			*16 230	*16 230	*11 400	10 390	*9 190	6 650	7 560	4 680			*5 640	3 920	8.3
	3.0 m kg					*13 370	9 580	*10 040	6 300	7 380	4 520			*5 820	3 600	8.7
	1.5 m kg					*14 620	8 910	10 110	5 970	7 190	4 350			5 730	3 480	8.7
	0 m kg					*14 490	8 590	9 850	5 750	7 060	4 230			5 870	3 550	8.5
	-1.5 m kg			*10 490	*10 490	*13 190	8 520	9 750	5 660	7 010	4 190			6 370	3 830	8.0
	-3.0 m kg					*10 790	8 620	*8 290	5 710					*6 120	4 500	7.2
Boom: 5.95 m 2-piece Arm: 3.6 m Shoe: 600 mm CWT: 4 950 kg	9.0 m kg													*5 510	*5 510	5.8
	7.5 m kg							*6 460	*6 460					*4 960	*4 960	7.3
	6.0 m kg							*6 830	*6 830	*6 280	4 900			*4 780	4 150	8.2
	4.5 m kg			*7 580	*7 580	*8 160	*8 160	*8 090	6 810	*7 370	4 780			*4 790	3 620	8.8
	3.0 m kg					*12 480	9 870	*9 560	6 430	7 460	4 590	5 590	3 430	*4 970	3 330	9.2
	1.5 m kg					*14 170	9 090	10 210	6 050	7 240	4 390	5 490	3 340	5 290	3 220	9.2
	0 m kg			*6 890	*6 890	*14 630	8 620	9 880	5 770	7 060	4 230	5 410	3 270	5 390	3 260	9.0
	-1.5 m kg			*10 640	*10 640	*13 860	8 450	9 710	5 620	6 970	4 150			5 780	3 470	8.6
	-3.0 m kg			*15 820	*15 820	*11 980	8 480	*9 120	5 610	*6 730	4 170			*6 220	3 970	7.8
-4.5 m kg					*8 710	8 680	*6 450	5 760							6.6	

Notes: 1. Machine in "Fine Mode-F" (Power Boost) for lifting capacities. 2. The above loads are in compliance with SAE J1097 and ISO 10567 Hydraulic Excavator Lifting Capacity Standards. 3. Rated loads do not exceed 87% of hydraulic lifting capacity or 75% of tipping load. 4. Rated loads marked with an asterisk (*) are limited by hydraulic capacity rather than tipping load.

LIFTING CAPACITY EC250ELR

Lifting capacity at the arm end without bucket.

For lifting capacity including bucket, simply subtract actual weight of the direct fit bucket or the bucket with quick coupler from the following values.

	Lifting point	0 m		1.5 m		3.0 m		4.5 m		6.0 m		7.5 m		9.0 m	
		Along UC	Across UC	Along UC	Across UC	Along UC	Across UC	Along UC	Across UC	Along UC	Across UC	Along UC	Across UC	Along UC	Across UC
Boom: 10.2 m LR Arm: 7.85 m LR Shoe: 800 mm CWT: 6 200 kg	3.0 m kg					*4 270	*4 270	*7 550	*7 550	*5 480	*5 480	*4 410	*4 410	*3 750	*3 750
	1.5 m kg					*1 460	*1 460	*5 150	*5 150	*6 700	6 630	*5 160	4 910	*4 260	3 790
	0 m kg					*1 550	*1 550	*3 490	*3 490	*7 670	5 950	*5 820	4 460	*4 720	3 490
	-1.5 m kg			*1 510	*1 510	*2 010	*2 010	*3 370	*3 370	*6 290	5 510	*6 330	4 130	*5 100	3 240
	-3.0 m kg	*2 080	*2 080	*2 070	*2 070	*2 550	*2 550	*3 690	*3 690	*5 980	5 260	6 410	3 910	4 970	3 060
	-4.5 m kg	*2 510	*2 510	*2 640	*2 640	*3 140	*3 140	*4 200	*4 200	*6 260	5 150	6 270	3 780	4 850	2 950
	-6.0 m kg	*3 000	*3 000	*3 230	*3 230	*3 790	*3 790	*4 860	*4 860	*6 880	5 130	6 220	3 740	4 790	2 900
	-7.5 m kg	*3 530	*3 530	*3 850	*3 850	*4 500	*4 500	*5 660	*5 660	*7 790	5 190	6 240	3 750	4 800	2 900
	-9.0 m kg			*4 530	*4 530	*5 290	*5 290	*6 610	*6 610	*7 920	5 310	6 330	3 830	4 850	2 950
	-10.5 m kg					*6 190	*6 190	*7 790	*7 790	*7 150	5 510	*5 790	3 970	*4 780	3 060
	-12.0 m kg							*7 560	*7 560	*5 990	5 790	*4 860	4 190	*3 950	3 260
	Lifting point	10.5 m		12.0 m		13.5 m		15.0 m		16.5 m		Max. reach		m	
		Along UC	Across UC	Along UC	Across UC	Along UC	Across UC	Along UC	Across UC	Along UC	Across UC	Along UC	Across UC		
Boom: 10.2 m LR Arm: 7.85 m LR Shoe: 800 mm CWT: 6 200 kg	13.5 m kg											*1 090	*1 090	12.4	
	12.0 m kg					*1 160	*1 160					*1 030	*1 030	13.7	
	10.5 m kg					*1 740	*1 740					*990	*990	14.7	
	9.0 m kg					*2 100	*2 100	*1 360	*1 360			*980	*980	15.5	
	7.5 m kg			*2 360	*2 360	*2 330	*2 330	*1 790	*1 790			*970	*970	16.1	
	6.0 m kg			*2 540	*2 540	*2 450	2 320	*2 120	1 850	*1 010	*1 010	*990	*990	16.5	
	4.5 m kg	*2 970	*2 970	*2 760	2 750	*2 610	2 210	*2 430	1 780	*1 370	*1 370	*1 010	*1 010	16.8	
	3.0 m kg	*3 320	3 240	*3 010	2 590	*2 780	2 100	*2 620	1 700	*1 600	1 380	*1 050	*1 050	17.0	
	1.5 m kg	*3 670	3 010	*3 260	2 430	*2 970	1 980	2 590	1 620	*1 740	1 330	*1 110	*1 110	17.0	
	0 m kg	*4 000	2 790	*3 500	2 270	2 980	1 870	2 510	1 540	*1 750	1 280	*1 190	*1 190	16.9	
	-1.5 m kg	4 160	2 610	3 430	2 140	2 880	1 770	2 440	1 480	*1 570	1 240	*1 290	1 210	16.7	
	-3.0 m kg	4 010	2 480	3 320	2 040	2 800	1 700	2 390	1 430			*1 430	1 240	16.3	
	-4.5 m kg	3 920	2 380	3 250	1 970	2 750	1 650	2 360	1 400			*1 610	1 290	15.8	
	-6.0 m kg	3 870	2 340	3 210	1 930	2 730	1 630	*2 020	1 400			*1 870	1 390	15.1	
	-7.5 m kg	3 860	2 330	3 210	1 930	2 740	1 640					*2 260	1 540	14.2	
-9.0 m kg	3 910	2 380	3 270	1 980							*2 890	1 780	13.0		
-10.5 m kg	*3 970	2 480									*3 410	2 180	11.6		
-12.0 m kg											*3 530	2 940	9.7		

Notes: 1. Machine in "Fine Mode-F" (Power Boost) for lifting capacities. 2. The above loads are in compliance with SAE J1097 and ISO 10567 Hydraulic Excavator Lifting Capacity Standards. 3. Rated loads do not exceed 87% of hydraulic lifting capacity or 75% of tipping load. 4. Rated loads marked with an asterisk (*) are limited by hydraulic capacity rather than tipping load.

Equipment

STANDARD EQUIPMENT

Engine

Turbocharged, 4 stroke diesel engine with water cooling, direct injection and charged air cooler that meets EU Stage V requirements

Air filter with indicator

Air intake heater

Cyclone precleaner

Electric engine shutoff

Fuel filter and water separator

Fuel filler pump: 50 l/min, with automatic shutoff

Alternator, 80 A

Electric / Electronic control system

Advanced mode control system

Selfdiagnostic system

Machine status indication

Engine speed sensing power control

Automatic idling system

Onetouch power boost

Safety stop/start function

Adjustable LCD color monitor

Master electrical disconnect switch

Engine restart prevention circuit

Highcapacity LED lights:

- Frame-mounted 2

- Boom-mounted 1

Batteries, 2 x 12 V / 170 A

Start motor, 24 V / 5.5 kW

Frame

Access way with handrail

Tool storage area

Punched metal antislip plates

Counterweight:

4 950 kg

6 200 kg Long Reach

Undercarriage

Undercover (heavyduty)

Hydraulic track adjusters

Greased and sealed track link

Track Guard

Hydraulic system

Boom up swing priority function

Boom travel priority function (Creep)

Boom down speed control

Hose rupture valve: boom & arm

Overload warning device

Automatic sensing hydraulic system

Summation system

Boom priority

Arm priority

Swing priority

ECO mode fuel saving technology

Boom, arm and bucket regeneration valves

Swing antirebound valves

Boom and arm holding valves

Multistage filtering system

Cylinder cushioning

Cylinder contamination seals

Auxiliary hydraulic valve

Automatic twospeed travel motors

Hydraulic oil, longlife oil 46

STANDARD EQUIPMENT

Cab and interior

ROPS (ISO121172) certified cab

Silicon oil and rubber mounts with spring

Travel pedals and hand levers

Adjustable operator seat and joystick control console

Proportional joysticks with 3 switches

Heater & airconditioner, automatic

Flexible antenna

Radio with MP3 & USB Jack with bluetooth

Hydraulic safety lock lever

Cab, allweather sound suppressed, includes:

Cup holders

Door locks

Tinted glass

Floor mat

Horn

Large storage area

Pullup type front window

Removable lower windshield

Seat belt

Safety glass

Sun screens, front, roof, rear

Rain shield

Windshield wiper with intermittent feature

Rear view camera

Side view camera

Master key

Track shoes

600 mm with triple grousers

800 mm with triple grousers Long Reach

Digging equipment

Boom: 6.0 m monoblock

Arm: 2.97 m

Boom: 10.2 m monoblock, Long Reach

Arm: 7.85 m, Long Reach

Manual centralized lubrication

OPTIONAL EQUIPMENT

Engine

Block heater: 120 V, 240 V

Oil bath pre-cleaner

Diesel coolant heater, 10 kW

Water separator with heater

Auto engine shutdown

Reversible fan

Delayed engine shutdown

Electric

Extra work lights(Halogen or LED):

Cab-mounted 3

Boom-mounted 1

Counterweight-mounted 1

Green light beacon

Travel alarm

Anti-theft system

Rotating warning beacon

Smart connect for tilt rotator

Tilt rotator 3rd gen

Dig assist, smart connect

Undercarriage

Full track guard

Track shoes

700/800/900 mm with triple grousers

600 mm HD with triple grousers

600/700 mm with double grousers

OPTIONAL EQUIPMENT

Hydraulic system

CDC, Comfort Driving Control
Boom float function with HRV
Boom float function without HRV
Attachment management system (up to 32 programmable memories)
- Variable flow and pressure pre-setting
Hammer & shear, 1 and 2 pump flow
Additional return filter
Hydraulic piping:
- Slope & rotator
- Grapple
- Oil leak (drain) line
Quick coupler piping
Volvo hydraulic quick coupler S1
Volvo hydraulic quick coupler S2
Volvo hydraulic quick coupler U25
Volvo hydraulic quick coupler S70
Volvo hydraulic quick coupler SQ70 55
Volvo hydraulic quick coupler SQ70
Hydraulic oil, biodegradable 46
Hydraulic oil, longlife oil 32
Hydraulic oil, longlife oil 68
Straight travel pedal

OPTIONAL EQUIPMENT

Cab and interior

High visibility cabin
Fabric seat with heater
Fabric seat with heater and air suspension
Deluxe seat
High-strength one piece front windshield (P5A)
Opening top hatch
Falling object guard, FOG (fixed type or hinge type)
Frame-mounted
Cab-mounted
Cab-mounted falling object protective structure (FOPS)
Volvo smart view
Smoker kit (ashtray and lighter)
Safety net for front window
Lower wiper with intermittent control
Anti-vandalism kit
Specific key
Cleaning air gun

Digging equipment

Boom: 6.0 m monoblock, heavy duty
Boom: 5.95 m 2 piece boom
Boom: 10,2 m monoblock, long reach
Arm: 2.5 m HD, 2.97 m HD, 3.6 m
Arm: 7.85 m, long reach
Linkage with lifting eye
Machine controls
Dig Assist
Volvo Active Control (Semi-autonomous)
Please refer to separate Brochure for more details

Service

Tool kit, daily maintenance
Tool kit, full scale
Automatic lubrication system

SELECTION OF VOLVO OPTIONAL EQUIPMENT**Two-piece boom****Swing out FOG****Demolition package****TiltRotator****Volvo Smart View****Comfort Drive Control**

Not all products are available in all markets. Under our policy of continuous improvement, we reserve the right to change specifications and design without prior notice. The illustrations do not necessarily show the standard version of the machine.

V O L V O