



613B



623B



633D

CAT ELEVATING SCRAPERS

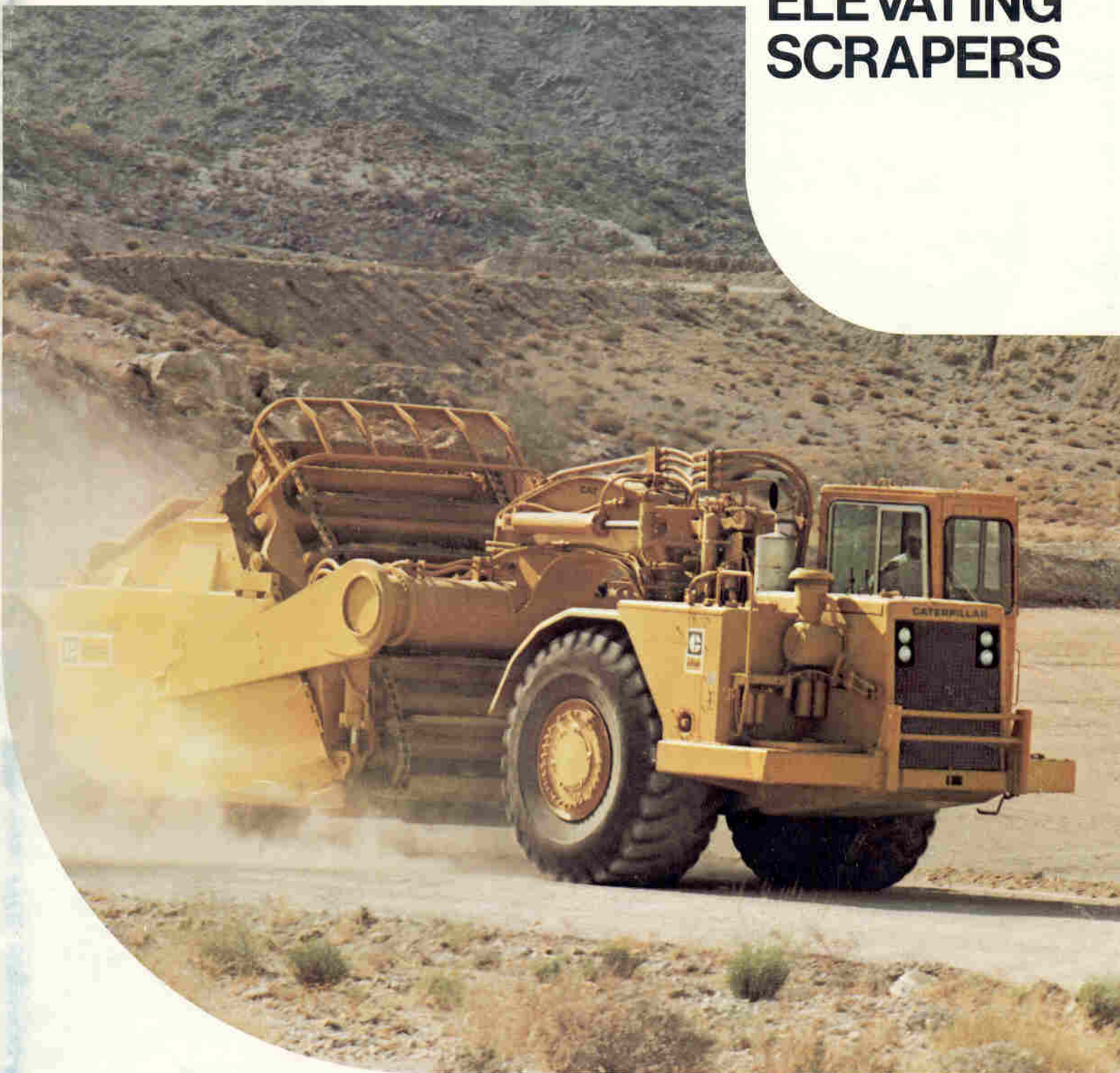

VERSATILITY



Cat Elevating Scrapers... One Man Production Machines

An elevating scraper must work by itself. Without trouble. And since you depend on work-alone reliability, Caterpillar designs-in the performance you need. Performance that means versatile production — day after day, job after job . . . from spreading and mixing soil to windrow clean-up and production hauling.



The **613B** at 11 cu. yd. (8.4 m³) heaped, is mobile, versatile and economical to own and operate. The proven Cat 3208 engine and power shift transmission make it a reliable performer.

- **Flywheel Horsepower** 150
- **Top Speed, Empty** 26 mph (42 km/h)
- **Weight Loaded** 55,330 lb. (25 100 kg)



The **623B** is a 22 cu. yd. (16.8 m³) heaped machine. The reliable 3406 engine, 8-speed semi-automatic transmission, variable capacity torque converter and cushion hitch arrangement keep it producing wherever you put it to work.

- **Flywheel Horsepower** 330
- **Top Speed, Empty** 31 mph (50 km/h)
- **Weight Loaded** 120,090 lb. (54 480 kg)



The **633D** is the workhorse of the elevating scraper line. Powered by the 3408 engine, it has all the features of the 623B, plus a 34 cu. yd. heaped (26 m³) capacity. The 633D is a machine you can work hard in all terrains.

- **Flywheel Horsepower** 450
- **Top Speed, Empty** 32 mph (48 km/h)
- **Weight Loaded** 174,000 lb. (78 930 kg)

Materials and specifications are subject to change without notice.

RELIABILITY

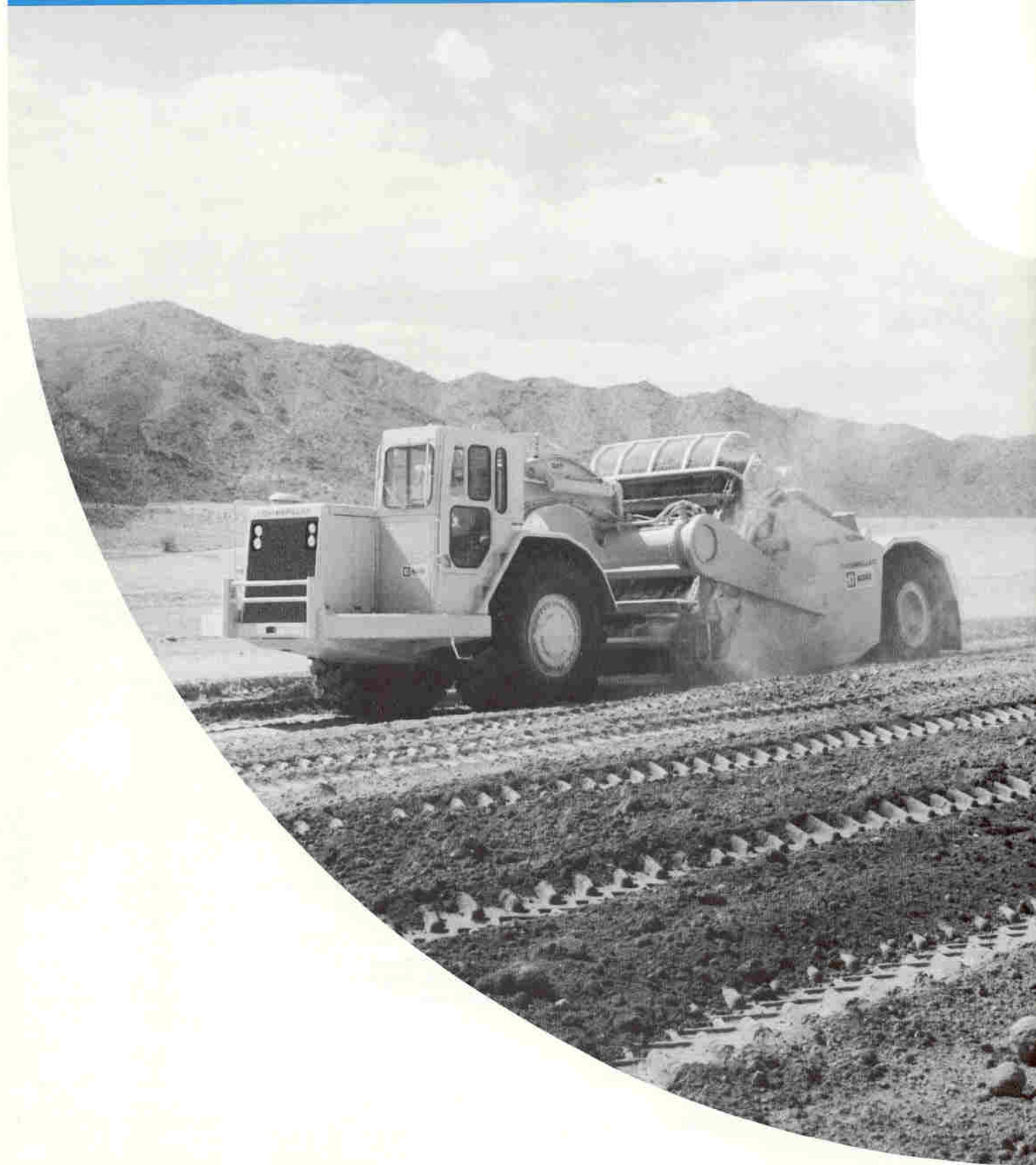

A Key to High Productivity ... Cat Elevating Scrapers

Each component — piston ring to final drive system — is developed, tested and carefully matched with other components to best meet the versatile operational needs of Cat Elevating Scrapers.

Turbocharging Boosts Power by packing more air into the combustion chamber. This burns fuel more efficiently, raising the power produced per cubic inch . . . and keeps the basic engine compact.

Turbocharging automatically compensates for the reduction of oxygen at high altitudes and temperatures so the machine can operate at full rated power. (Caterpillar specification sheets show altitudes to which machines will deliver full rated power.)

Aftercoolers improve turbocharging by lowering intake air temperature. This makes the air more dense and further increases the oxygen available for combustion. This can boost output and help to keep the machine's power package compact.

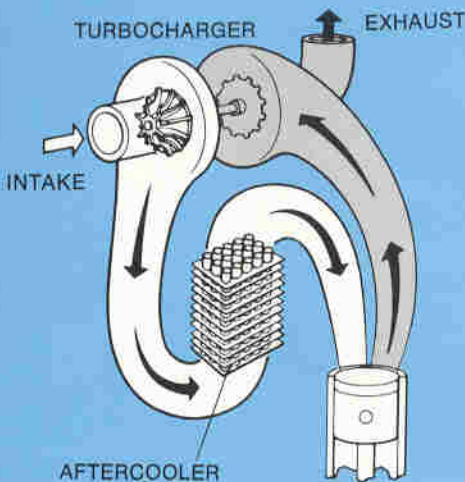

LONG-LIFE ENGINE COMPONENTS



Variable fuel timing on 623B and 633D advances or retards injection automatically according to engine speed. Result: easier starting, better acceleration and excellent response.



Strong grey iron blocks have internal ribs and deep-seated bearing saddles to maintain perfect alignment of crankshaft and bearings.

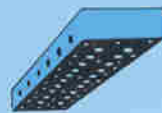

Cylinder heads are cast of special alloyed grey iron with a minimum specified tensile strength of 40,000 psi (2800 kg/cm²).



Valves rotate 3° per lift on the 623B and 633D for better heat dissipation and longer life, and seat on nickel-base-alloy replaceable inserts.



Elliptically-shaped pistons allow heat expansion to . . . reduce wear-causing ring-roll, wipe liner walls cleaner for minimum oil consumption . . . provide for maximum power generation.



Forged crankshafts are statically and dynamically balanced, with precision ground, hardened and super-finished journals.



613B steering. Variable-flow modulation gives you complete, precise control. A special valve meters hydraulic flow in the first part of the steering wheel turn for fast response with little effort. The system is designed to meet your need for close quarter maneuvering. **623B, 633D steering.** Constant-velocity, hydraulic follow-up systems on the two larger machines answer the demands for efficient haul road performance and easy operation. The action and feel are just like that of an automotive steering system.



Tractor final drives are planetary design, with Duo-Cone® Floating Ring Seals to protect the double-row roller bearings.



Cat-built differential lock means extra traction in soft or muddy ground. It locks the drive wheels together so neither can spin free. Disengaged, it allows normal differential action.



Brakes, like the engines, match the machine and its application. The 613B has air-over-oil caliper disc brakes for fade-resistant stopping power. The 623B and 633D have air-actuated expanding shoe brakes on all wheels . . . and are synchronized to apply the scraper brakes first. (Brake systems meet OSHA requirements.)

FAST CYCLING



Fast, Smooth Performance with Easy Operator Control

Precisely matched Cat transmissions and torque converters provide a dependable, optimum flow of power for hydraulics and final drives. Shifting console design is less fatiguing and demanding on your operator. He is assured of predictable, precise machine response — essential for fast, efficient work cycles.

Variable Capacity Torque Converter for 623B and 633D provides four loading positions for optimum match of ground speed and loading conditions. The torque converter has two impellers which can be controlled to determine the amount of horsepower available to the wheels and to the hydraulic system.

The outer impeller is controlled by a clutch. **When the clutch is engaged** (gears 1 and 2), the outer and inner impellers rotate as one to provide maximum available rimpull.

When the outer impeller freewheels (load range 1 or 2), torque converter capacity and rimpull are at a minimum. Maximum horsepower is then available to the hydraulic system for elevator operation.

Using the single lever transmission control, your operator simultaneously controls the converter and transmission to match ground speed and elevator hydraulics to varying job conditions.

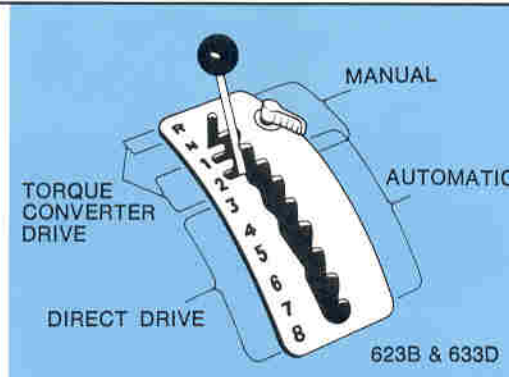
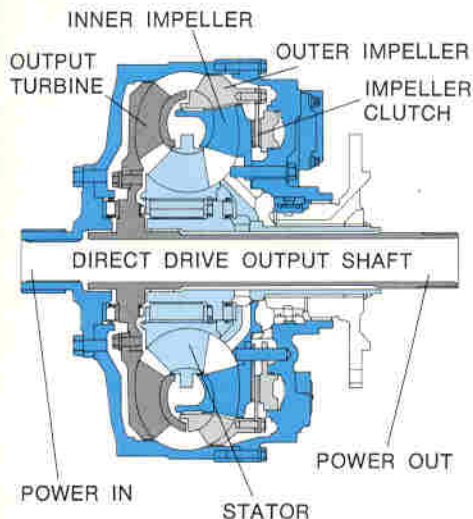

Cat 8-speed semiautomatic transmission combines automatic shifting with high torque multiplication and direct drive mechanical efficiency. Reverse, 1st and the highest desired gear are manually selected. The transmission automatically shifts up or down between 2nd and the highest selected gear. Reverse, 1st and 2nd gears are torque converter drive . . . providing powerful rimpull for loading and dumping. Gears 3 thru 8 are direct drive for quick acceleration and high hauling speeds.



613B features four manually selected, power shift speed ranges forward and two reverse . . . and full torque converter drive for high torque and anti-stall performance.

Cat Power Shift Transmissions are built around a center shaft with planetary-gear-set clusters stacked end-to-end to conserve space and for even load distribution. Large diameter clutch plates and discs afford high leverage and holding capabilities . . . stationary clutch design provides for exceptionally tight seals. All of which means long component life and reliable transmission response.

Cat Hydraulic Modulation system assures smooth speed and direction changes . . . dampens shock on power train components and on operator . . . promotes faster cycles with fast, lively machine response.

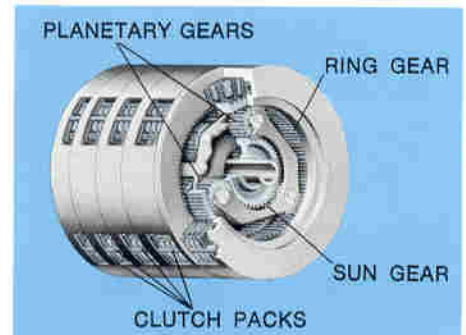

Cat's Planetary Power Shift Transmission

- assures smooth transmission of engine torque
- eliminates rough mechanical shifting
- promotes long, efficient transmission life
- reduces operator fatigue
- enhances overall productivity

LOADING



With power and with speed - without pusher assistance

The power to self-load is the real measure of Cat Elevating Scrapers. And their power and self-sufficiency is job-proven . . . top-soil stripping, wind-row pick-up, trenching, finish grading, terracing to production hauling. You can't beat the versatility of Cat's 613B, 623B and 633D self-loading scrapers.

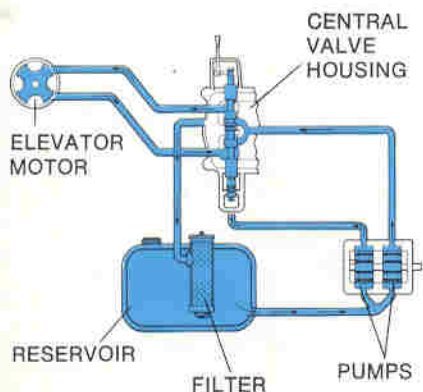

Hydraulic Drive System is sealed and filtered. Particles worn from pumps or motors are immediately caught by the filters. The circuit has no breather-type venting, no chance for dirt to enter the circuit to cause premature wear.

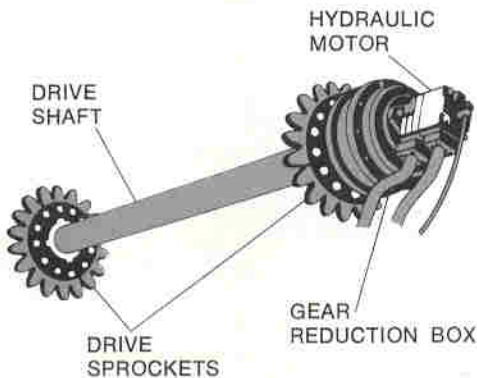

High-torque Hydraulic Drive turns the elevator at a relatively constant speed under heavy loads. This lets the operator select the best loading depth without continual adjustment. Leaves the cut smooth for easier, more efficient loading on the next pass.

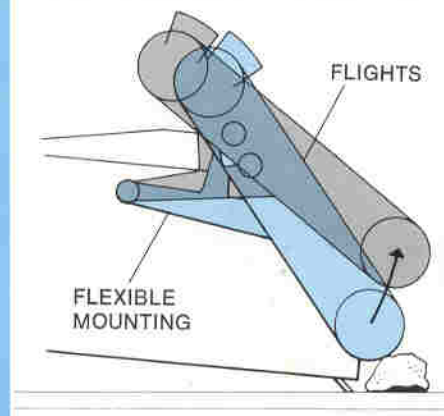

Cat's Flexible Mounting protects elevator flights and cutting edge against sudden shock. Elevator is free to swing upward to accommodate rocks or other large objects . . . quickly returns to position to keep loading the bowl.

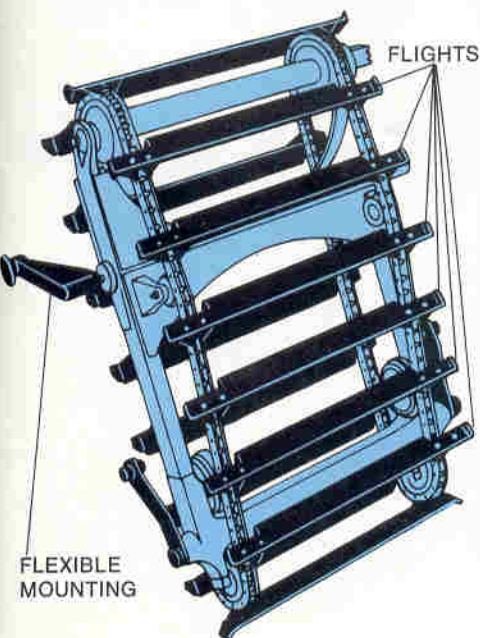

The 623B and 633D flights are modified box-section high-strength steel . . . the 613B has a rugged, modified triangular flight.

Chain pins and bushings are high-wear-resistant, heat-treated alloy steel. Chain bushing life is lengthened because special design prevents bushings from contacting roller guide flanges.

Engine-driven implement pump powers the elevator hydraulic motor. The

motor turns the elevator chains and flights . . . through a specially-designed planetary gear reduction box, employing a live, double sprocket drive shaft.

Drive Sprocket Teeth can be renewed without removing elevator chain or disturbing alignment . . . by replacing split bolt-on rims.

Cat elevator chains have exceptionally high pull-strength (see chart). This buffer zone is your protection from high impact loading damage.

Built-In Protection	613B		623B		633D	
	lb.	kg	lb.	kg	lb.	kg
Min. Pull-Strength Built into Chain	60,000	27 200	120,000	54 400	135,000	61 200
Max. Pulling Force Applied to Chain	12,400	5 600	18,000	6 160	31,000	14 060
RESERVE STRENGTH	47,600	21 600	102,000	46 260	104,000	47 200

SPREADING



Fast, clean, fully controlled ... in less than ten seconds

Your operator has full control . . . he can dump the scraper's full bowl load . . . or, if he needs to, he can spread that same load evenly over a predetermined area. Cat Elevating Scrapers are built for efficient productivity.

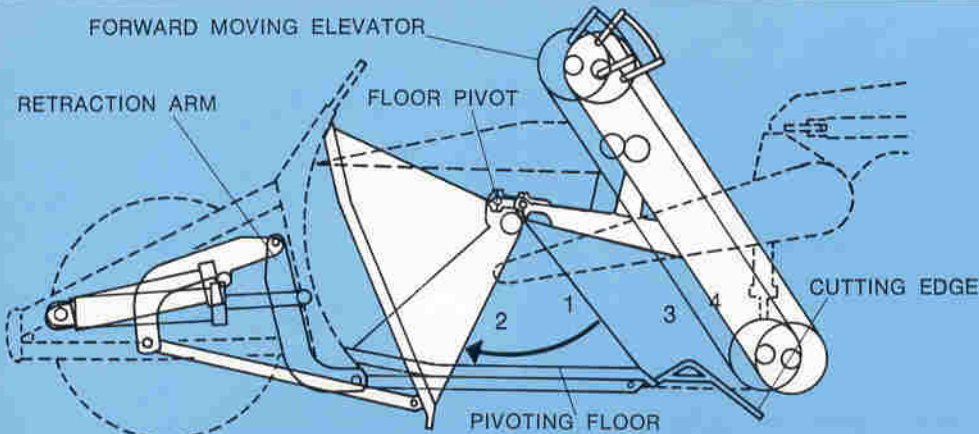

633D Pivots the entire floor for metered spreading or mass dumping. The scraper floor pivots (1-to-2) back and up from the fixed cutting edge. This action also serves to clean the bowl sides and back. At the same time, the elevator moves forward (3-to-4) and out of the way. This prevents material from being forced into the flights, and affords an even larger opening for mass dumping.

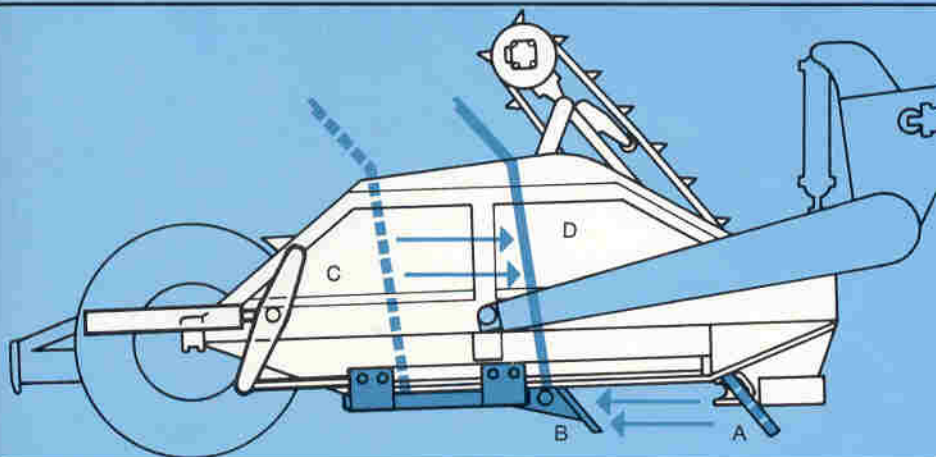

613B and 623B Eject in two smooth, fully-operator-controlled steps. (1) Scraper floor and cutting edge slide back (A-to-B) about half the floor's length for a large opening. (2) Simultaneously, the dozer-ejector moves (C-to-D) forward to the cutting edge, forcing out all materials, cleaning the sides and floor. Double-acting control cylinders give positive force in both directions. Fast and effective.

Operator Controls are smooth and precise. Response and performance are reliable.

Three Levers for hydraulic actuation:

Elevator . . . 2 speeds fwd., 1 rev.

Bowl . . . raise, hold, lower control

Ejection . . . dump, hold, return control.

Detent held with automatic kickout on dump and return. Dump position may be held to override kickout.

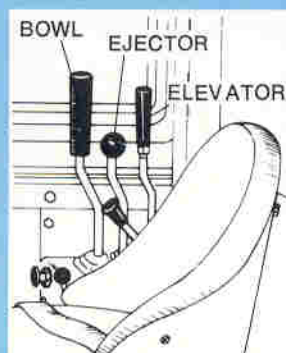

Elevator Speeds (at rated engine speed)

	613B	623B	633D
Forward			
Low-High	116-225 fpm (35-69 m/min.)	245-330 fpm (83-110 m/min.)	200-300 fpm (61-91 m/min.)
Reverse	116 fpm (35 m/min.)	164 fpm (50 m/min.)	200 fpm (61 m/min.)

PRODUCTIVITY



Increased Production and Improved Operator Ride

Production is important. So Caterpillar provides a smoother, more comfortable ride and excellent handling characteristics so your operator can concentrate on production rather than operation.

Less bounce equals more speed . . .

Cushion Hitch means higher usable travel speeds over rough roads. Standard on the 623B and 633D. Cushion Hitch reduces machine loping and levels out washboarded haul roads. Located between the tractor and draft frame, it is a shock absorbing connection that permits vertical movement between tractor and scraper. This dampens the bounce and harmonic lobe on the haul and return for:

- higher, usable speeds
- reduced operator fatigue
- additional long haul applications
- reduced haul road maintenance
- longer machine life, less maintenance.

Operator can lock out the Cushion Hitch for maximum down pressure at the cutting edge when loading . . . or for maximum control of the lift while unloading.

Optional ROPS, sound-suppressed cab combines operator protection and comfortable work environment in a totally enclosed operator's compartment. The frame of the compartment is an integral all-welded ROPS — entirely secured on rubber mountings that isolate the operator from noisy vibrations. Meets all existing OSHA standards for roll over protection and sound suppression.

Visibility is vital when the cut or fill gets crowded. That's why Caterpillar elevating scrapers offer excellent visibility, both to the front for traveling and to the rear for loading.

Caterpillar-built retarders are available as factory installed attachments for the 623B and 633D. They let you select auxiliary braking from zero to maximum on long downhill runs, to reduce wear on service brakes. There are six complete ranges. You can modulate the retarder in each range with a lever on the steering column.

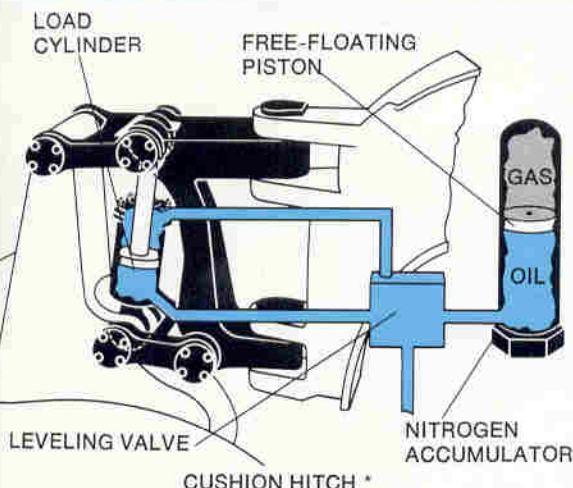

*Cushion hitch not available on 613B

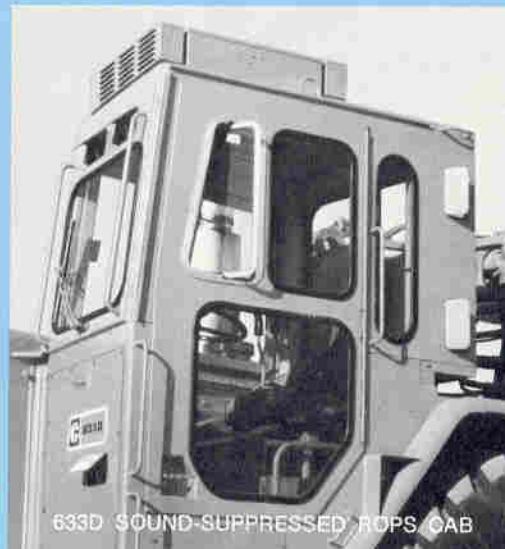

633D SOUND-SUPPRESSED ROPS CAB

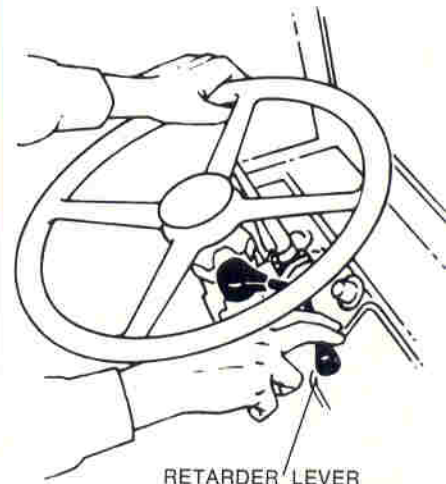

RETARDER LEVER

EQUIPMENT





Dependable Dealer Service

You get more than just a machine when you purchase from your Caterpillar Dealer. Because you also get CAT PLUS — a total customer support commitment. Investigate the many programs that are specially designed to eliminate downtime, save repair and maintenance and help you get more life, more productivity from your Cat-built equipment. Things like:

Inspection programs to let you catch minor problems before they become major repairs. On-the-job technical analysis by a qualified inspector keeps a careful check on equipment performance to assure top running condition.

Parts Exchange includes engines, transmissions and torque converters to keep machines working without extensive downtime. You replace a failed component with a factory-rebuilt one, and get your machine back to work fast.

Product Application Service can carefully analyze your job layout and determine exactly the proper type and amount of equipment to perform your job most efficiently.

Personnel Training is available to thoroughly prepare your operators and mechanics for working with Caterpillar-built machines.

NEBRASKA MACHINERY COMPANY

 **YOUR CATERPILLAR DEALER**

NORTH PLATTE

SCOTTSBLUFF

E330